

CPD Webinar series

Guidance documents and tools for producing a compliant design

Speaker | Frances Hall
Weir Legal & Consulting

Speaker | German Ferrando-Miguel
VBA – Office of the State Building Surveyor

ā rbv



Architects
Registration Board
of Victoria



Acknowledgment of Country

We respectfully acknowledge the Traditional Owners of the lands wherever attendees are situated, in particular the Wurundjeri People of the Kulin Nation, and pay our respects to their Elders past and present.



Summary of webinar content

- Need for design compliance in production of building designs
- Governed by Building Act, Building Regulations and National Construction Code
- Design requirements can be complicated and difficult to interpret
- First recourse should be to the legislation or the National Construction Code provisions
- There are reference documents to guide production of a design
- Reference documents include:
 - Ministerial Guidelines
 - VBA Practice Notes
 - NCC Guidance Materials
- The Building Act amendment to provide for Binding determinations – what are they, who issues them and what is their effect?
- What is the legal effect of each of those documents and when and how should they be used?

Ministerial Guidelines – what are they?

- Ministerial Guidelines are documents issued by the Minister who has authority in relation to Building Act matters.
- They are issued pursuant to a power given in the Building Act.
- Ministerial Guidelines have the force of law i.e. they must be complied with and any interpretation given in them is binding.

Ministerial Guidelines – what do they contain?

- There are 15 Ministerial Guidelines currently in force under the Building Act.
- Not all will be relevant to architects
- Those likely to be relevant:
 - MG-12 Siting and Design of Single Dwellings (recently updated to respond to planning changes relating to Small Secondary Dwellings)

Ministerial Guidelines – MG-12

- Siting and design are typically managed through planning permits
- Part 5 of Building Regulations sets out generic siting and design requirements for class 1a buildings on a site.
- Where report and consent is sought for a variation to the Part 5 requirements, MG-12 must be followed by the reporting authority.
- Architects and building designers should know how MG-12 operates so they can gauge whether a variation to the siting and design requirements is likely to be approved.

Minister's Guideline

MG-12: Siting and Design of Single Dwellings



Siting and Design of Single Dwellings

[Published in the Government Gazette, S 677 on 14 December 2023]

I, the Hon. Sonya Kilkenny MP, as the Minister administering the *Building Act 1993 (Act)*, hereby issue this Guideline under section 188A of the Act concerning the siting and design requirements relevant to an application for a building permit for a single dwelling, including a principal single dwelling, a small second dwelling or a front fence.

This Guideline takes effect on the date it is published in the Victoria Government Gazette.

I revoke all Minister's Guidelines, MG-12: Siting and Design of Single Dwellings, issued before the date on which this Guideline takes effect.

Purpose of this Guideline and Interpretation

The purpose of this Guideline is to set out the matters to be considered by a reporting authority when preparing a report on, and considering whether to consent to, (**report and consent**) a variation to the siting, design and access requirements prescribed under Part 5 of the Building Regulations 2018 (**Regulations**), for an application for a building permit for a single dwelling, including a principal single dwelling, a small second dwelling or a front fence.

Each provision of this Guideline comprises a statement of the objective and the matters to be considered when deciding whether the objective is met. Under clause 4A of Schedule 2 of the Act, a reporting authority must have regard to the guidelines made under section 188A in the cases set out in that clause. If any matter set out in this Guideline is not met, clause 4A(2)(d) of Schedule 2 to the Act requires that the reporting authority must refuse to give its consent to an application for a building permit.

In this Guideline—

- **existing dwelling** is a single dwelling that is already constructed;
- **principal single dwelling** is a single dwelling that is not a small second dwelling or a front fence;
- **Regulations** means the *Building Regulations 2018*;
- **single dwelling** has the same meaning as it has under section 188A(4) of the Act and regulation 70 of the Regulations: a building, or buildings, which is a Class 1 building and any Class 10 building associated with a Class 1 building, that is or are intended to be used as a dwelling;
- **small second dwelling** has the same meaning as it has under regulation 5 of the Regulations. (A **small second dwelling** is defined to mean a Class 1a building that is self-contained and has a gross floor area that is equal to or less than 60 m² on the same allotment as an existing building that is a single Class 1 building that is not a small second dwelling).

Siting requirement 1: Maximum street setback of a principal single dwelling

MG-12 – how it operates

- 17 siting requirements set out in MG-12, including:
 - Maximum and minimum street, side and rear setbacks
 - Small second dwelling street, side and rear setbacks
 - Building height
 - Site coverage
 - Private open space and overshadowing of recreational private open space
- For each siting requirement the guidelines sets out the criteria that the reporting authority must consider. Includes things like:
 - Amenity of existing neighbouring dwellings
 - Disruption to streetscape

Other potentially relevant Ministerial Guidelines

- MG-03 – Involvement of adjoining owners in siting appeals. Governs how a Council should decide a request for a reduced setback in terms of the views of neighbouring owners.
- MG-11 – Building permit and planning permit consistency. Governs how this is assessed and what matters are relevant.
- MG-13 – Exercise of discretion when applying a new building regulation or amendment to a building regulation. Governs how a building surveyor decides which version of the NCC should apply to the design.
- MG-15 – Remediation work proposal for mitigating cladding risk for buildings containing combustible cladding

Where to locate Ministerial Guidelines for Building Act issues

- <https://www.vba.vic.gov.au/building/building-resource-hub/minister-guidelines>

VBA Practice Notes – What are they?

- Practice Notes are documents issued by the VBA which provide guidance on interpretation of requirements under the Building Act, including design requirements.
- Two categories of Practice Note:
 - Building
 - Plumbing
- Each category of Practice Note have a large number of practice notes issued. They are categorised by issue type.

VBA Practice Notes – what are they used for?

- They are designed for use by building practitioners, including building designers and also architects. Each Practice Note specifies the intended audience, which frequently includes architects.
- They provide guidance in how to practically apply the requirements set out in the Building Act 1993, the Building Regulations 2018 and the National Construction Code.
- They may give examples of how the provisions should be applied.
- They do not have the force of law. They provide guidance but do not have effect as a legislative tool themselves.

VBA Practice Notes – what are they used for?

- They are designed for use by building practitioners, including building designers and also architects. Each Practice Note specifies the intended audience, which frequently includes architects.
- They provide guidance in how to practically apply the requirements set out in the Building Act 1993, the Building Regulations 2018 and the National Construction Code.
- They may give examples of how the provisions should be applied.
- They do not have the force of law. They provide guidance but do not have effect as a legislative tool themselves.

VBA Practice Notes – when are they used?

- By building surveyors when reviewing design documents for a building permit application or when issues arise during construction.
- By Councils when considering Building Act issues e.g. a report and consent application.
- In Building Appeals Board proceedings or other court proceedings, the parties might refer to them in support of their interpretation of how the law applies to a particular building issue.

Roof Plumbing RP 02 | Box Gutters'

Audience

The audience/s for this Practice Note include/s:

- | | |
|--|--|
| <input checked="" type="checkbox"/> Architects/ Designers | <input checked="" type="checkbox"/> Owner Builders |
| <input checked="" type="checkbox"/> Builders | <input checked="" type="checkbox"/> Plumbers |
| <input checked="" type="checkbox"/> Building Surveyors/ Inspectors | <input type="checkbox"/> Real estate management agents |
| <input checked="" type="checkbox"/> Engineers | <input checked="" type="checkbox"/> Trades and Maintenance (inc. Electricians) |
| <input type="checkbox"/> Home Owners / Residential Tenants | |

Purpose

This Practice Note provides guidance on the Deemed-to-Satisfy (DtS) requirements for the installation of box gutters with sole widths between 200mm and 600mm.

The content below provides guidance on:

- Defining a box gutter
- Design and installation parameters for box gutters
- Requirements for a box gutter support system
- Overflow provisions in a box gutter
- Expansion provision for box gutters
- Collaboration on the design of box gutters



For guidance on regulatory framework, please refer to Plumbing Practice Note RF-01 | Regulatory Framework- NCC

Abbreviations & Definitions

The abbreviations and definitions set out below are for guidance only. They are not intended to vary those set out in the Building Act 1993, the Plumbing Regulations 2018 or the National Construction Code.

- **Act** – Building Act 1993
- **NCC** – National Construction Code 2022
- **AS** – Australian Standard
- **AS/NZS** - Australian/New Zealand Standard
- **DtS** – Deemed-to-Satisfy
- **PCA**– Plumbing Code of Australia (National Construction Code 2022, Volume Three)



Defining a box gutter

A box gutter is defined as a graded channel, generally of rectangular shape, for the conveyance of rainwater within the building footprint, typically adjacent to a wall or parapet. A box gutter incorporating a lear is also an acceptable shape, provided the minimum sole widths are observed and the effective cross-sectional area of the gutter is appropriately sized for the roof catchment area.

All box gutter installations, whether new or replacement must satisfy the Performance Requirements of the Plumbing Code of Australia (PCA). The Performance Requirements apply to the design, construction, installation, replacement, repair, alteration and maintenance of box gutters. Compliance with the Performance Requirements of the PCA are automatically satisfied by complying with the AS/NZS 3500.3 and HB 39. Alternatively, they can be demonstrated through the Performance Solution process as set out in Section 2 of the PCA. Typical examples of box gutters are shown in Figure 1.

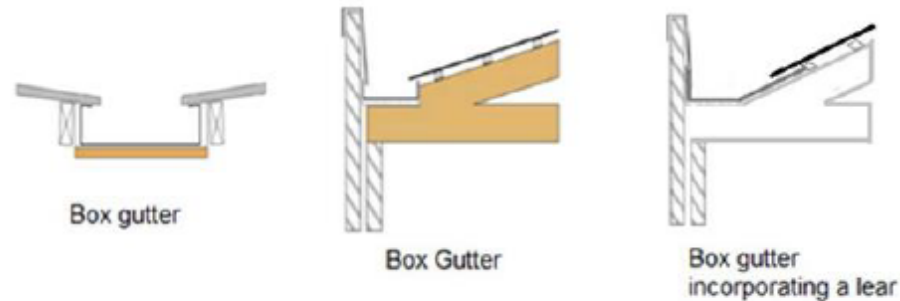

Figure 1: Typical examples of box gutters



V-shaped gutters are not permitted. If installed, they may result in water damage to the building. Damage may be caused by premature failure of the gutter due to inadequate drainage, permanent ponding and debris accumulating in the crevices, which may lead to intense localised corrosion of the gutter.



Guidance on the [Plumbing Regulatory Framework](#) and the use of [Performance Solutions](#) can be found on the [VBA website](#)



Image 1: Examples of non-DtS box gutter installations

Image 1 depicts 3 examples of non-DtS box gutter installations. Designs such as these can only demonstrate compliance with the Performance Requirements of the PCA through the Performance Solution process.

Deemed-to-Satisfy requirements for a box gutter support system

Box gutter support systems shall be designed and manufactured to support the entire weight of the gutter and sumps when full of water, and a trafficable load at any point in the gutter and sumps. For guidance on vertical load testing refer to AS/NZS 2179.1

The sides of each box gutter must have adequate structural strength so that water pressure will not cause deformation.

The box gutter support system must be fabricated from a material that is compatible with the box gutter or alternatively, the gutter must be protected against corrosion from an incompatible support material, or where exposed to a corrosive environment. The support system must be resistant to UV degradation and be securely attached to the building structure.

There are two types of DtS box gutter support methods that are available in the standard. These are:

- **Continuous support system** - where the box gutter is supported by multi-ribbed metal roof sheeting or other sheet type material. The support system must be continuous across the full length and sole width of the box gutter. The support of the sheet material must be fit for its intended purpose. Incompatible sheet materials may be used provided the contact surfaces are lined with a non-abrasive, impervious, non-conducting material. Continuous support systems are suitable for all gutter sole widths.
- **Discontinuous (bracket) support system** - where the box gutter is supported by brackets positioned at stop ends, either side of the sump and rainheads. The bracket material must be compatible with the box gutter and located at intervals not exceeding 750mm. Discontinuous support system can only be used for box gutters having a sole width less than 450mm.

Figure 2 provides an example of both types of box gutter support systems.

VBA Practice Notes – where can they be found?

- They can be obtained from the VBA website:
<https://www.vba.vic.gov.au/building/building-resource-hub/practice-notes>
<https://www.vba.vic.gov.au/plumbing/plumbing-resource-hub/plumbing-practice-notes>
- Also, the AIA is publishing new Practice Notes as they get released, through their fortnightly newsletter.
- The Practice Notes go through a process of periodic review and update. Always check you are using the most up to date version.

QUESTION 1

What is the legal status of VBA Practice Notes?

- (a) They are incorporated by reference into the Building Act
- (b) They provide authoritative guidance but aren't binding
- (c) They are binding on registered building practitioners

Binding Determinations: what and why

What: Not just a tool, but a legislative function of the SBS under the Building Act 1993

- They are an interpretation of a standard or requirement
 - They are a “standards-setting” tool, NOT a compliance management tool
 - They are enforceable, NOT guidance or advice
- They cover building work or plumbing work as prescribed by the existing framework and must not be inconsistent with the Act or the regulations
 - Not to create new obligations outside of the existing framework
 - Not to modify existing regulations or standards
 - Not to impose new standards or administrative requirements
 - Interpretation must be anchored and consistent within the existing framework
- Must be published in VBA’s website and gazetted for the duration of the binding determination
 - Starts on the date of publication or as gazette and can be revoked
 - Maximum duration is 10 years

Why

- Provide an enforceable tool that prescribes interpretation of technical standards and requirements
- Focusing on instances where divergent interpretation is prominent and can lead to specific harms

Binding determinations: Where and When

Where

- They sit within the broader objectives and functions of the State Building Surveyor to drive improved building system performance and policy outcomes via:
 - improvement in standards/regulatory frameworks, and
 - support practitioners with advice, guidance and education.
- These empower the VBA to implement the C&E Policy Framework by providing clarity of what's required.

When

- We will use this new powerful tool strategically focusing on areas of existing concern and in alignment with VBA's Regulatory Policy Statement
- BDs to be issued proactively initially (no avenue for industry applications yet).
- They might be appealed to the Supreme Court of Victoria

Binding determinations: How

- The decision-making framework for BDs and the associated protocol needs to be integrated within that overall improvement/problem solving objective.
- A decision by the SBS to issue a binding determination will consider if another tool or action may be better suited to achieve the desired regulatory outcome.
- Process to issue BDs might involve targeted consultation and/or specialist studies.
- We are adopting a continuous improvement approach in the implementation of Binding Determinations. We will continue to use our existing tools, with BDs to add value where required.
- BDs might be used in conjunction with education, regulatory or standard changes.
 - BDs are different from Practice Notes. They have strict enforceability and become the law. Where evidence that a harm remains, despite existence of a practice note, then a BD might add value.
 - Efforts to change standards, regulations or legislation to provide long term clarity will remain. BDs might be used as a temporary measure if that process takes too long.

QUESTION 2

What does the SBS need to do once a BD is issued?

- 1) Send e-mail to industry
- 2) Publish a note in VBA's website
- 3) Publish in Victorian Gazette
- 4) Publish the Binding Determination in VBA's website and in Victorian Gazette

Binding determinations and architects (hypothetical)

H8P1 Livable Housing Design (PR)

A Class 1a building must be provided with—

- (a) a continuous and step-free path to a dwelling entrance door from either—
 - (i) the pedestrian entry at the allotment boundary; or
 - (ii) an appurtenant Class 10a garage or carport; or
 - (iii) a car parking space provided for the exclusive use of the occupants of the dwelling; and
- (b) at least one level and step-free entrance door into the dwelling from the access path required by (a); and
-

H8D2 Livable Housing Design (DtS)

(1) A Class 1a dwelling must comply with the ABCB Standard for Livable Housing Design.

(2) Clause 1.1 of the ABCB Standard for Livable Housing Design need not be complied with if—

- (a) step-free access via an appurtenant garage, carport or parking space in accordance with Clause 1.1(1)(b) or (c) is not provided; and
- (b) one or more of the following conditions exist:
 - (a) The average slope of the ground on which the access path would be constructed exceeds a gradient of 1:14.
 - (b) To provide an external step-free access path would necessitate construction of ramping that exceeds the length and gradient allowed by Clause 1.1(4).
 - (c) There is insufficient space available on the site on which to construct a step-free access path complying with Clause 1.1.

Is the DESIGN not providing sufficient space, or the SITE not having enough space for step-free access?

Is the criteria in H8D2(a) about step-free access not provided, or the garage/carport/parking space not provided?

Does the exemption in H8D2 also exempt the design from the requirement in H8P1(a)(i) and H8P1(b)?

A Binding Determination might be the right tool to interpret those questions and provide clarity to architects

QUESTION 3

Can the SBS issue a Binding Determination to prescribe a change to H8D2?

1. Yes, BDs apply to technical standards and H8D2 is a technical standard
2. Yes, BDs can change standards when they are not clear
3. No, BDs cannot change a standard, only interpret it if not clear

NCC Guidance Materials – What are they?

- These are documents prepared and issued by the Australian Building Codes Board (ABCB).
- They provide advice and guidance on the application of provisions of the NCC in various areas.
- Various forms of documents:
 - Handbooks
 - Infographics
 - Guidelines
 - Guidance Note

NCC Guidance Materials – what are they used for?

- Large number of guidance materials issued by ABCB
- Can be content specific, such as:
 - Thermal bridging;
 - Guttering, downpipes and overflow
 - Condensation in buildings
- Or may group topics together to create a handbook, such as:
 - Apartment energy efficiency handbook;
 - Livable housing design handbook;
- Alternatively may relate to process, such as:
 - Performance solution process
 - Using assessment methods
 - Bushfire verification methods

NCC Guidance Materials – example

- Example of guidance note on Thermal Bridging, issued Oct 2023:
 - Gives practical explanation of what it is;
 - What the NCC provisions require;
 - How it applies to houses for:
 - Roofs and ceilings;
 - External walls.
 - How it applies to sole occupancy units for:
 - Roofs and ceilings;
 - External walls
 - How it applies to common areas in apartment buildings
 - How to fix thermal bridges



The NCC Performance Requirements can be met using either a Performance Solution, Deemed-to-Satisfy (DTS) Solution, or a combination of both.

The following is a general representation and introduction to the DTS Provisions for thermal bridging in residential buildings.

It covers the DTS Provisions for thermal bridging in Class 1 buildings (houses), the sole-occupancy units (SOUs) of Class 2 buildings (apartments) and common areas of Class 2 buildings (apartment buildings). The information presented provides a national overview of the NCC and does not contain any state or territory variations.

This information is useful for architects, building designers, façade engineers, builders, and environmentally sustainable design (ESD) consultants.

What is thermal bridging?

Thermal bridging, in practical terms for the NCC, is an unintended path of heat flow between the outside and inside of the building.

Thermal bridges may occur where there is an interruption in the insulation or where highly conductive materials (e.g. metal) are used.

As an example, if a steel truss roof directly supports an insulated corrugated iron roof, the heat flows through the truss more

readily than the surrounding insulation, negating the effect of the insulation (i.e. the truss acts as a thermal bridge).

Figure 1 Metal roof truss



What are the impacts of thermal bridging?

Thermal bridges can significantly reduce the effectiveness of the insulation (thermal resistance) of the façade by essentially bypassing the insulation in favour of a more conductive material (e.g. metal). This results in either losing heat from inside the building to the outside on a cold day, or adding warmth to the inside the building on a hot day. This may cause unwanted comfort issues in a building, and a likely increase in energy use by a building's heating and cooling systems.

Additionally, unaddressed thermal bridges may lead to condensation where warm, moist air contacts a colder surface and condenses into water droplets. Condensation can result in mould growth, causing indoor air quality issues, negative health impacts for occupants, and potentially affects the durability of the structure.

Thermal bridging and the NCC

The NCC prescribes methods for reducing thermal bridging in the following construction types:

- metal sheet roofing fixed to metal purlins, metal rafters or metal battens
- lightweight external wall cladding (such as weatherboards, fibre-cement or metal sheeting) fixed to a metal frame.

The NCC also requires thermal bridging to be considered when calculating the Total R-Value/Total System U-Value in the following construction types:

- steel and timber frames in the building envelope
- windows
- spandrel panels.

While the NCC does not prescribe methods for the following construction types, thermal bridging may also occur in:

- junctions between the floor, wall and roof
- penetrations in the building envelope for pipes and cables
- brackets or connection points for external shades or balconies
- slab projections
- steel wall ties used in masonry construction.

Case studies on thermal bridging of commercial construction

The ABCB has some detailed NCC Volume One case studies showing how to calculate Total R-Values with thermal bridges.

The case studies show the impact of thermal bridging using different materials in different climates zones.

Case study 1

Fibre cement cladding on timber framed stud wall for a Class 3 residential building in climate zone 5

Case study 2

Solid concrete, steel framed stud wall for a Class 6 shop in climate zone 3

Case study 3

Flat (horizontal) steel sheet roof with steel framing for a Class 7 storage facility in climate zone 6

Total R-Value and Total System U-Value: A recap

Total R-Value and Total System U-Value describe thermal resistance/transmittance (i.e. the ability of heat to transfer through a system or material). These values relate to one another, with the R-Value being the inverse of the U-Value.

Typically, R-Value is used to refer to a material's ability to prevent heat flow from a cold environment to a warm environment. Whereas, U-Value is used to describe a materials ability to transfer heat from a warm environment to a cold environment.

When using the NCC, R-Value ($m^2.K/W$) means the thermal resistance of a component, such as a layer of insulation. It is calculated by dividing its thickness by its thermal conductivity. The Total R-Value ($m^2.K/W$) means the sum of the R-Values of the individual component layers in a composite element, such as an external wall. It includes any building material, insulating

material, airspace, thermal bridging and associated surface resistances.

When using the NCC, Total System U-Value ($W/m^2.K$) means the thermal transmittance of the composite element allowing for the effect of any airspaces, thermal bridging and associated surface resistances.

To understand what a 'good' or 'bad' value is, the higher the Total R-Value, the better insulator it is, whilst the opposite is true for the Total System U-Value.

What are the effects of thermal bridging on the Total R-value or the Total System U-Value?

The thermal resistance (or transmittance) of an element relates to the whole assembly (e.g. the frame and glazing elements of a window) or the entire façade. Therefore, thermal bridges can cause considerable thermal inefficiency and significantly decrease the R-Value (or increase the U-Value) of an envelope component. This means a small thermal bridge can have a substantial impact on the overall heat transfer through the building envelope.

Fixing thermal bridges

While adding more insulation can help to account for thermal bridges, if they are to be truly fixed a thermal break is needed.

A thermal break is an element with low thermal transmittance placed strategically to interrupt the heat flow path through elements with high thermal transmittance.

Figure 1 provides an example of a thermal break in a spandrel panel. The thermal break is created by using a non-metal structural sealant, weather sealant, gasket and trim, as these have low thermal transmittance. The thermal break interrupts the connection between the inside and outside air through the metal mullion (with high thermal transmittance).

Figure 2 : Example of a spandrel panel with a thermal break (section view)

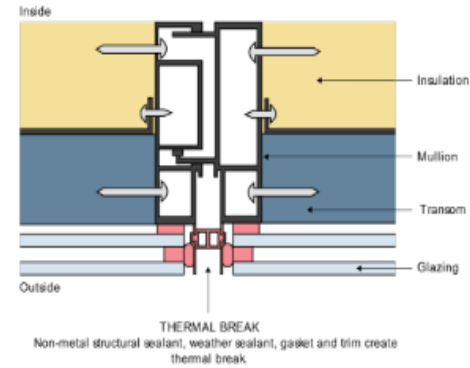

Calculating Total R-Values with thermal bridges

Total R-Values can be calculated with allowances for thermal bridging in accordance with AS/NZS 4859.2:2018 'Thermal insulation materials for buildings – Design'.

This Standard comprises of a calculation method (NZS 4214 'Methods of determining the total thermal resistance of parts of buildings') that accounts for the impact of thermal bridges on thermal performance.

Want to know more?

Examples showing how to calculate Total R-Values with thermal bridges are available separately from the ABCB website.

NCC Guidance Materials – where can they be found?

- They are located on the ABCB website, see link below:

<https://www.abcb.gov.au/resources/filter/guidance-material-and-handbooks>

QUESTION 4

Where different reference materials such as a binding determination, NCC guidance or VBA practice note appear inconsistent, which document should take priority?

Any questions?

 **ā** rbv



Architects
Registration Board
of Victoria

ARCHITECTS REGISTRATION BOARD OF VICTORIA

Address

Level 10, 533 Little Lonsdale Street
Melbourne VIC 3000

Phone number

03 9417 4444

Email

registrar@arbv.vic.gov.au